

Lifting and Moving Solutions

www.gksweb.com

**OPERATING AND MAINTENANCE INSTRUCTIONS No. 09 / 2011 FOR GKS-PERFEKT
TOE JACK MODEL V**





Lifting and Moving Solutions

www.gksweb.com

**OPERATING AND MAINTENANCE INSTRUCTIONS No. 09/2011 FOR GKS-PERFEKT
TOE JACK MODEL V**

KEEP THE OPERATING INSTRUCTIONS ALWAYS CLOSE WITH YOU !

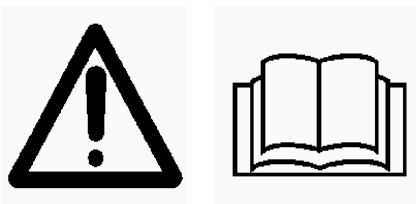

**Please read these instructions carefully
before using the jack!**

TEST CERTIFICATES



ANSI / ASME



SALES AND SERVICE

**GKS-PERFEKT LIFTING AND MOVING SOLUTIONS
LLC**

300 E. Auburn Avenue
Springfield, OH 45505
USA

phone: +1 (937) 324 - 8867
fax: +1 (937) 324 - 8171
e-mail: info@gksweb.com
website: www.gksweb.com

CONTENTS

	page
Contents	1
I. General information/Technical data	2
II. What to do before operation	3
III. How to operate the jack correctly	3/4
IV. What to check during operation	5
V. Sources of operating errors	6
VI. Safety instructions	7
VII. Storage and maintenance	8
VIII. Troubleshooting	9
IX. Extras: Separate hydraulic pump and QUADRO	10
X. Other tips	11
XI. EC Declaration of Conformity/Specifications	11



Lifting and Moving Solutions



www.gksweb.com

**OPERATING AND MAINTENANCE INSTRUCTIONS No. 09/2011 FOR GKS-PERFEKT
TOE JACK MODEL V**

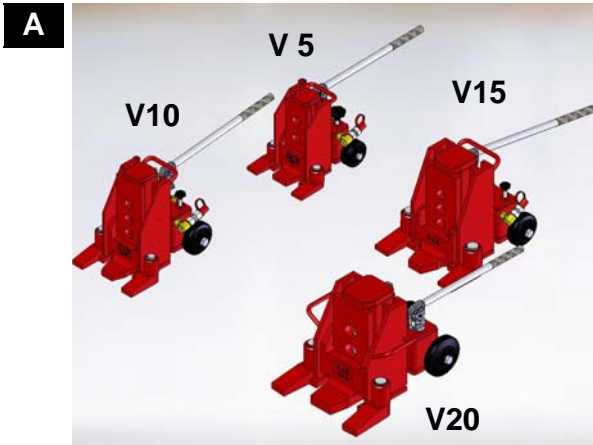

**I. GENERAL INFORMATION
APPLICATION**

Jacks designated Type V are designed for vertical lifting of machines and loads.

Max. operating pressure: 7542 psi (+ 435 psi) [520 + 30 bar]

MODE OF OPERATION (Pic B)

When the pump lever is manually operated, oil is routed from the tank into the lifting cylinder which then moves vertically to the top of the slides, and thereby lifts the load resting on the lifting toe (see diagram). Upon reaching the maximum operating pressure of 7542 psi (+435 psi) an integral safety valve opens to prevent lifting of loads heavier than the specified lifting capacity. Opening the discharging screw allows oil to flow back into the tank, the lifting piston returns to its lowest position and the load is lowered.

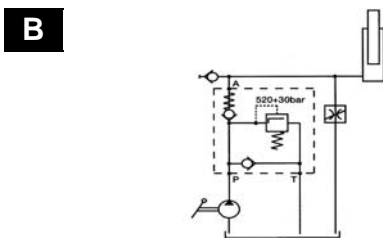

TECHNICAL DATA

Jack type	V5	V10	V15	V20
Total lifting cap. in lbs (t)	11,000 (5)	22,000 (10)	33,000 (15)	44,000 (20)
Dimensions in inch (mm)	L	10 ½ (260)	12 ½ (320)	18 (455)
	W	8 ½ (210)	9 ½ (240)	12 ½ (320)
	H	10 (255)	12 (310)	12 (310)
Oil capacity in gall. (l)	1/16 (0.25)	1/8 (0.6)	1/4 (1.0)	1/3 (1.3)
Weight approx. in lbs (kg)	46 (21)	70 (32)	116 (53)	159 (72)
Article-no.	10181	10182	10183	10184

SCHEDULE OF PARTS SUPPLIED

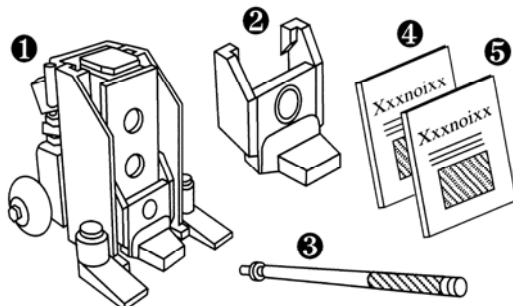

1. Jack assembly complete
2. Adjustable lifting toe
3. Pump handle
4. Operating instructions and maintenance manual
5. Inspection certificate

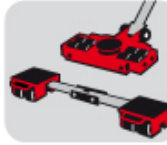
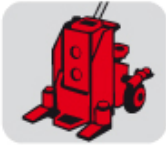

Lifting and Moving Solutions

www.gksweb.com

OPERATING AND MAINTENANCE INSTRUCTIONS No. 09/2011 FOR GKS-PERFEKT TOE JACK MODEL V

D

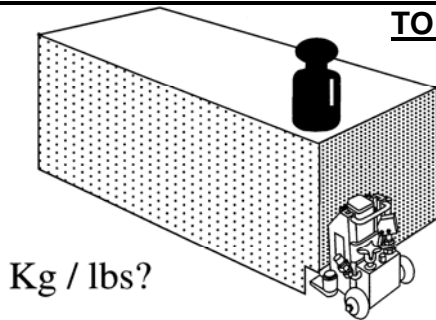

II. WHAT TO DO BEFORE OPERATION ?

WEIGHT/CENTER OF GRAVITY OF THE LOAD (Pic D)

Check the following before operation:

- the weight of the machine or load, to choose the jack suited best for the lifting operation
- locate the center of gravity of the machine or load, to find the most suitable point of lifting

FLOOR AND GROUND CONDITIONS (Pic E)

Ensure, that

- the jack is standing firm on a leveled floor and that
- the bottom of the housing has complete contact with the floor

E

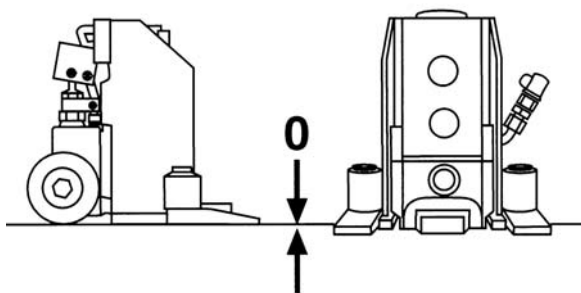

TOE HEIGHT FOR JACKS (Pic F)

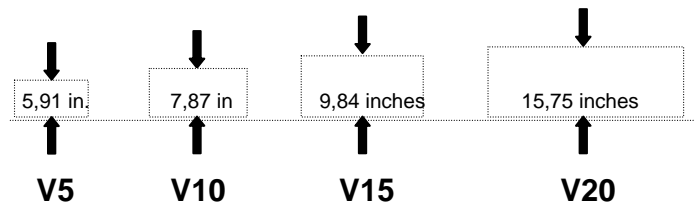

F

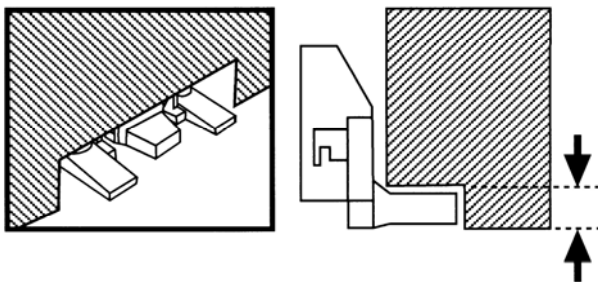

III. HOW TO OPERATE THE JACK CORRECTLY ?

(Pic G)

To operate correctly, you must

1. place the swivel feet in the direction of the load, then
2. pilot the lifting toe from above over the slider and
3. hook into the suitable hole of the front plate (depends on clearance height needed)

→ continuation on page 4

G

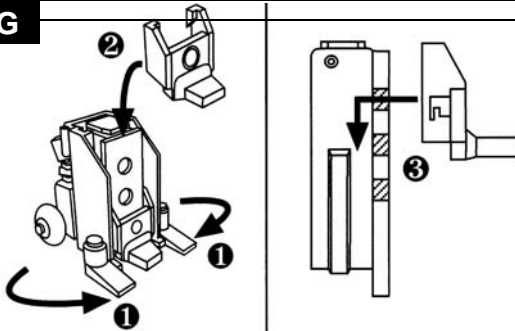



Lifting and Moving Solutions



www.gksweb.com

OPERATING AND MAINTENANCE INSTRUCTIONS No. 09/2011 FOR GKS-PERFEKT TOE JACK MODEL V

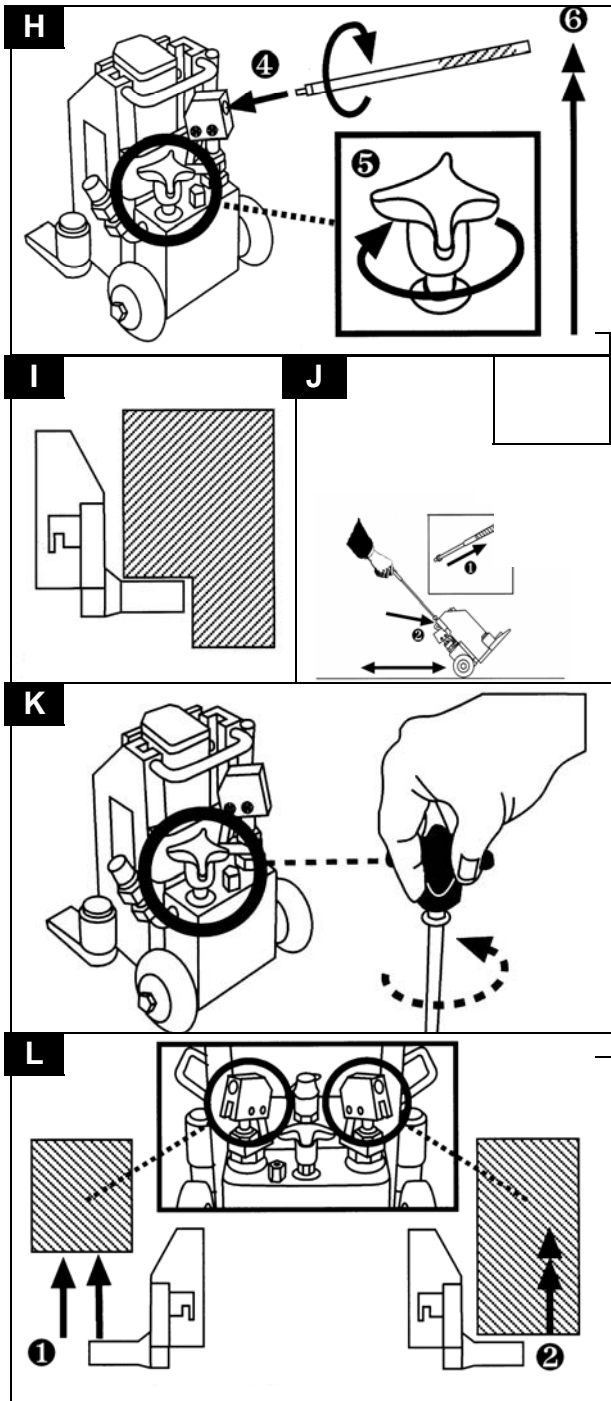

Contin.: HOW TO OPERATE THE JACK CORRECTLY (Pic H)

4. Next insert the pump lever into the plunger actuating block and screw in fully (clockwise)
5. Then turn (clockwise) the discharging screw firmly to ensure complete closure and
6. start pumping, to lift the load.

CONTACT POINT ON THE LIFTING TOE (Pic I)

Rest the load as near as possible to the back of the toe.

MOVING THE JACK (Pic J)

All models of jacks are equipped with wheels and a telescopic pump lever for safe and easy transportation.

Just screw the tip of the thinner end of the pump lever into the housing on the right at the top of the jack body.

LOWERING (Pic K)

Grip the handle of the discharging screw and carefully open anti-clockwise to lower the load (max. 1-2 turns)!

V20 JACKS (Pic L)

V20 jacks have an additional high displacement pump plunger to lift the jack tower more quickly whilst unloaded.

This has the advantage of requiring fewer pumps to engage the lifting toe under the load.

1. Fast pump: Only use to place the toe under the load (not suited for lifting of the load)
2. Working pump: For lifting load.

⚠ **Never use both pumps at once.**



Lifting and Moving Solutions



www.gksweb.com

OPERATING AND MAINTENANCE INSTRUCTIONS No. 09/2011 FOR GKS-PERFEKT TOE JACK MODEL V

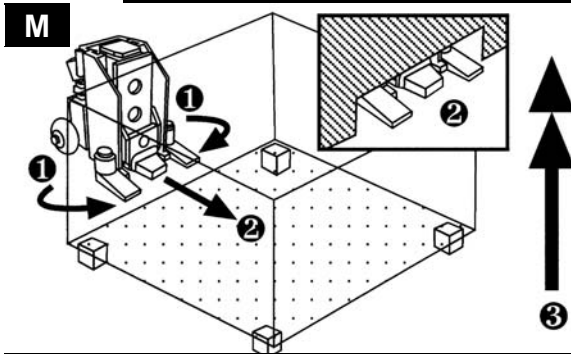

IV. WHAT TO CHECK DURING OPERATION ?

1.) possibility: DISTANCE BETWEEN BOTTOM OF LOAD AND FLOOR SURFACE (Pic M)

1. Place the swivel feet in direction of the load
2. Position the jack underneath the load to be lifted (check also the small pic) and then
3. use pump lever for pumping and lifting

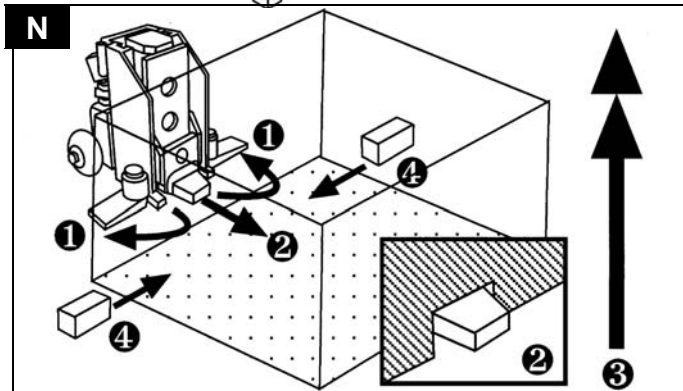

2.) possibility: NO CLEARANCE BETWEEN BOTTOM OF LOAD AND FLOOR SURFACE (Pic N)

1. Position swivel feet parallel to the load
2. Place jack with toe underneath the load
3. Start pumping and lifting just as much, that there is sufficient clearance for the feet
4. Place chocks underneath the load (hardwood, etc.)

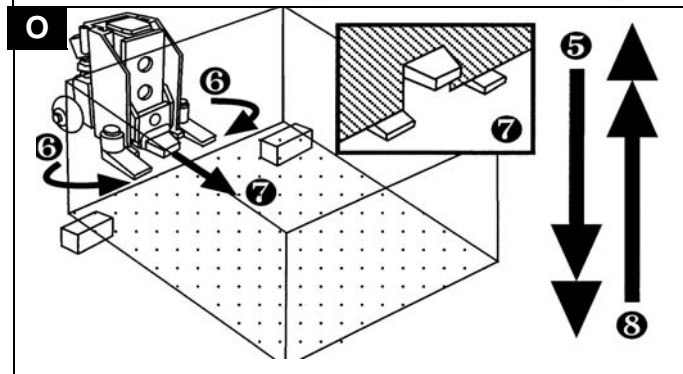

→ to be continued with Pic O

5. Lower the load onto the chocks
6. Position swivel feet now in direction of the load
7. Place jack again underneath the load and
8. start pumping and lifting again

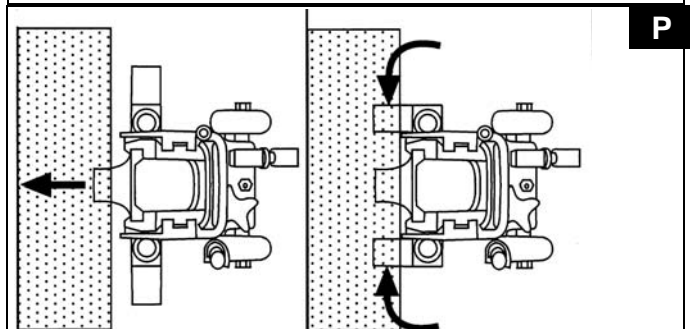

In order to clarify it, the plotting of the same operation in top view! (Pic P)

Plotting left: Lifting with feet parallel onto chocks like Pic N

Plotting right: Lifting from chocks to full height like Pic O



Lifting and Moving Solutions



www.gksweb.com

OPERATING AND MAINTENANCE INSTRUCTIONS No. 09/2011 FOR GKS-PERFEKT TOE JACK MODEL V

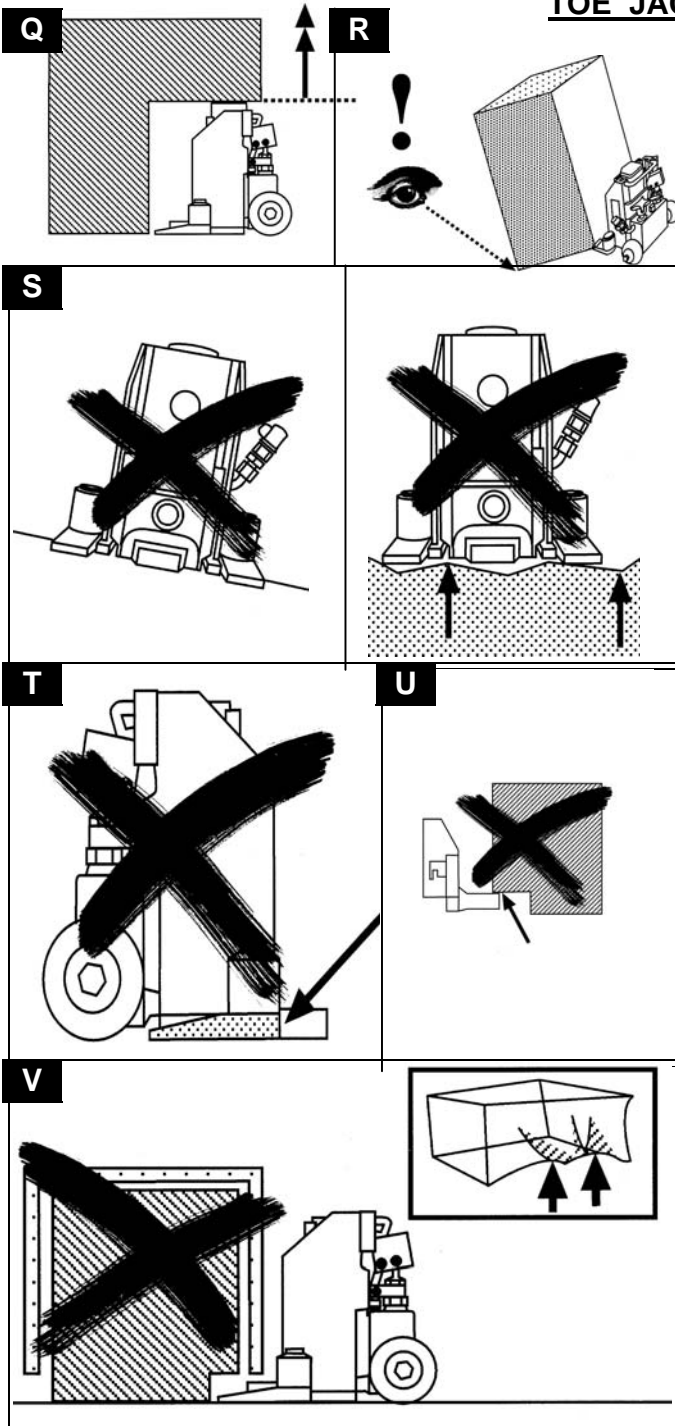

3.) possibility: LIFTING WITH THE HEAD OF THE JACK (Pic Q)

In case it is possible to place the jack with its full height underneath the load, you can also lift with the top plate of the slider. The full load capacity on top plate is the same as on top of the lifting toe!

⚠ **Always check that the swivel feet are turned forward under the load.**

SAFETY DURING LIFTING (Pic R)

Monitor constantly the stability of the machine during lifting operation. If it is observed after pumping several times that the machine may tilt, lower the machine and relocate the jack more towards the center of gravity.

⚠ **If the load is nose dive or has a high center of distribution (f.i. a radial drilling machine), then always use 2 jacks coupled together by an external pump (check also Pic AH on page 9)**

V. SOURCES OF OPERATING ERRORS

⚠ **Attention: Danger of injury**

- Never lower a load onto the jack top plate or lifting toe!

Result: Break of the latch and / or destruction of the jack when load exceeds jack's lifting capacity.

- Never use the jack in an angular position! (check Pic S left)
- Never use the jack on a non-level surface, without having complete contact of the bottom of the housing and of the swivel feet! (check Pic S right)

⚠ **The swivel feet and the base of the jack body must be in full contact with the floor surface.**

- Never use the jack, when the feet are completely swivelled to the rear! (Pic T)

Result: The jack may tilt towards the load, then will slip off to the back/side and the load will fall on the floor!

- Never place the load only on the tip of the lifting toe! (Pic U)

Result: The jack may tilt towards the, then will slip off to the back/side, the load will slip off the toe!

- Never position the jack under a sheet steel frame, a sheet steel panel or other points of lifting, which are not rigid enough to support the weight of the load! (Pic V)

Result: If you position the jack e.g. underneath the steel frame of a CNC lathe, then the deformation of the frame will be the consequence! (Pic V above right)



Lifting and Moving Solutions

www.gksweb.com

OPERATING AND MAINTENANCE INSTRUCTIONS No. 09/2011 FOR GKS-PERFEKT TOE JACK MODEL V

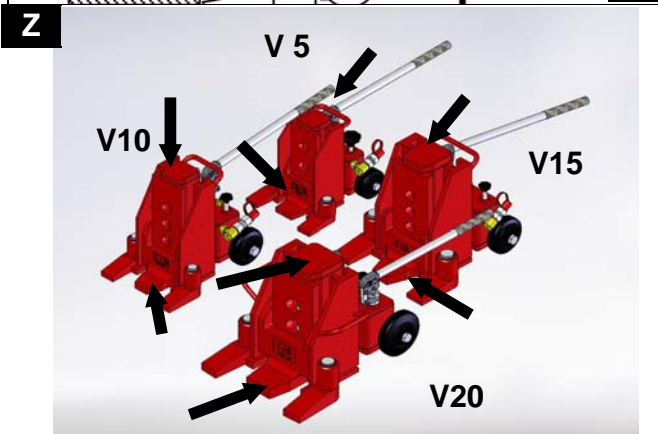
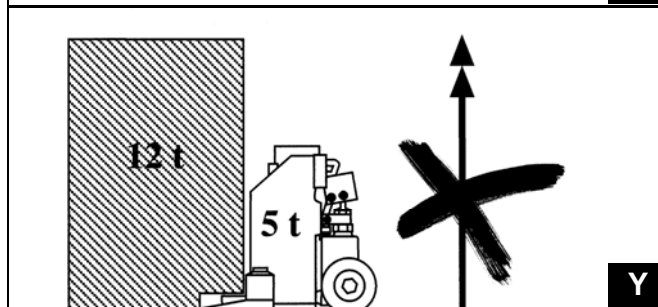
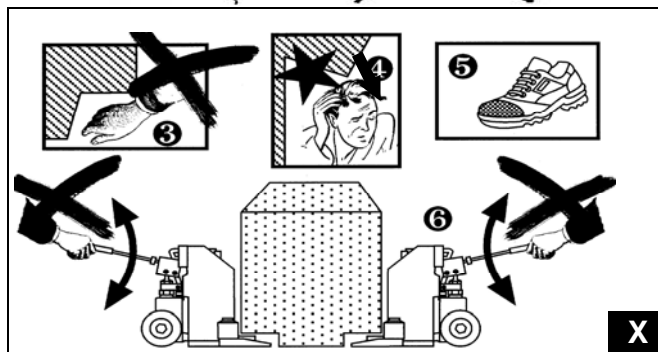
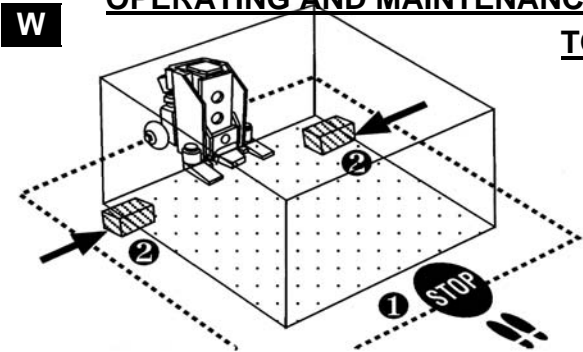

VI. SAFETY INSTRUCTIONS (Pic W and X)

1. Safety zone: Includes the load itself, the zone directly surrounding the load and an adequately large area surrounding the load which is measured according to the dimensions of the load so that -should the load tilt- sufficient area is available to prevent injury to persons. Make sure, that people who are not participating in the lifting procedure must not stand within the safety zone!
 2. Always check the load during lifting operation as well as after finishing the lifting procedure!
- ⚠ **Do not work underneath the load when the load lifted is still on the toe and the jack(s) are still under operating pressure. First secure the load with safety supports and lower the load onto chocks, etc.**
3. Never put body parts like arms, hands, feet or head underneath the load!
- ⚠ **Never touch the movable parts of the jack (f.i. slider, housing, toe etc.) during lifting and lowering procedure. This may result to clamping of clothes or body parts.**
4. Pay attention to overlapping components of the load. Do not stand in the vicinity of overlapping components.
 5. The operators must wear safety footwear.
 6. Simultaneous use of 2 or more jacks is permitted only when the jacks are coupled together by an external pump! If you don't use an external pump, it may result to variable load and thus tilting of the load. (check also Pic AH on page 8)!

(Pic Y)

- ⚠ **The different types of jacks are equipped with an integrated safety valve, which only works during the lifting process. The internal pressure of the jack is limited to 7542 psi (+ 435 psi) [≈ 520 bar (+ 30 bar)]. Therefore the maximum load capacity of each jack is limited to its permitted load. Lifting of loads with a capacity higher than the maximum capacity rated on the jack's identification plate is impossible!**

(Pic Z)

The contact area for the heavy loads are paste up with an anti-slip coating.

Is this anti-slip coating worn out (no rough surface anymore) the contact area must be replaced by a new one.

This anti-slip coating must be on the top plate and on the toe.



Lifting and Moving Solutions



www.gksweb.com

OPERATING AND MAINTENANCE INSTRUCTIONS No. 09/2011 FOR GKS-PERFEKT TOE JACK MODEL V

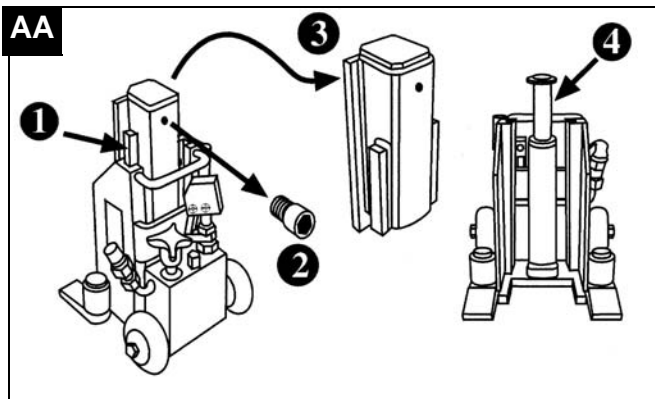

VII. STORAGE AND MAINTENANCE

- **Storage:** Only standing upright and in a dry and non-corrosive environment
- **Maintenance:** (Pic AA)
 1. Guides: grease them regularly.
 2. Lifting piston: grease it from time to time; remove screw of slider on the back (only for V5 on the right side).
 3. Remove slider upwards.
 4. Pump the lifting piston upwards, grease it and then press downwards to its lowest position.
 5. Clean air-vent screw with compressed air. (see Pic AB Pos.5)
- **Oil:** Change every year:

How to change the oil (Pic AB):

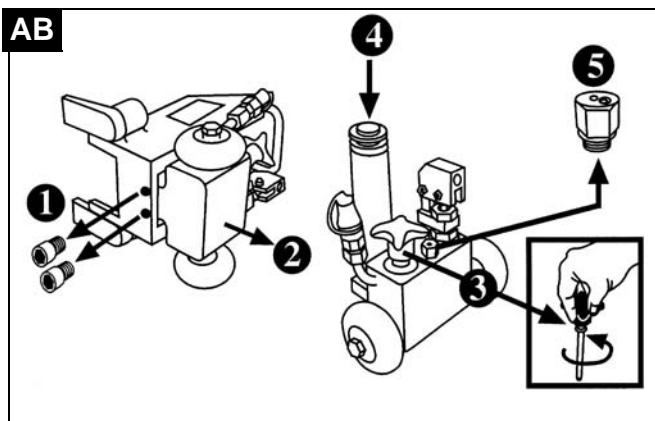

1. Unscrew both screws on the bottom side of the housing (Allen wrench size 6)
 2. Remove hydraulic unit backwards.
 3. Open lowering screw.
 4. Press down lifting piston.
 5. Screw out the air-vent screw (open-end wrench size 17).
→ see Pic AC
 6. Empty used oil
 7. Fill in new oil (specification in accordance with ISO ref. HLP46; to ensure perfect operation of the hydraulic system an air-space of 1" (25 mm) between oil surface and tank top plate must be available
- **Disposal of oil:** Used oil must be disposed in accordance with the statutory requirements.

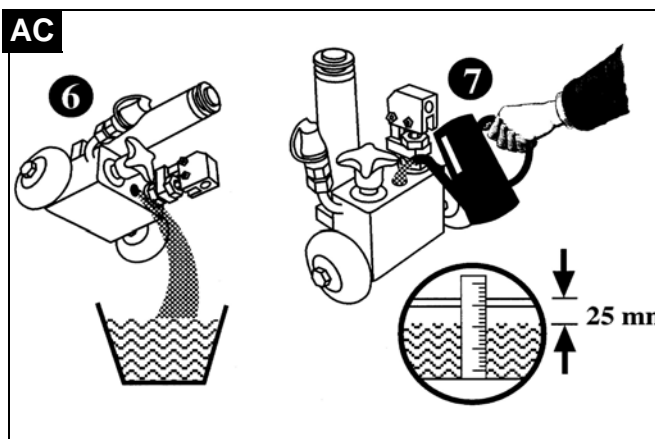

Oil amount	V5	V10	V15	V20
in gall.	1/16	1/8	1/4	1/3
(in l)	(0.25)	(0.6)	(1.0)	(1.3)

Oil specification	
ISO VG Ref.	HLP 46
AGIP	OSO 46
IP	Hydraus 46
BP	Energol HLP 46
ESSO	Nuto H46
MOBIL	DTE 25
SHELL	Tellus 46



Lifting and Moving Solutions



www.gksweb.com

OPERATING AND MAINTENANCE INSTRUCTIONS No. 09/2011 FOR GKS-PERFEKT TOE JACK MODEL V

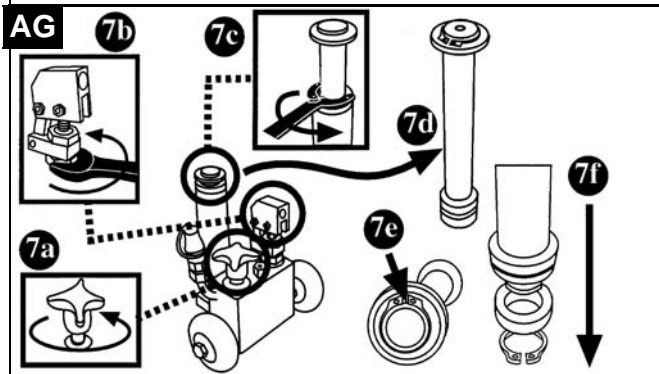
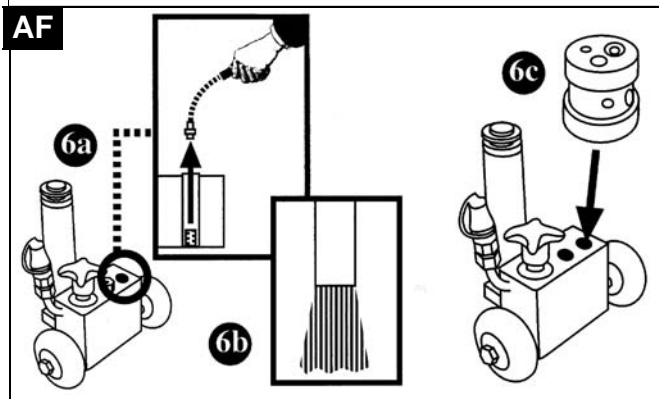
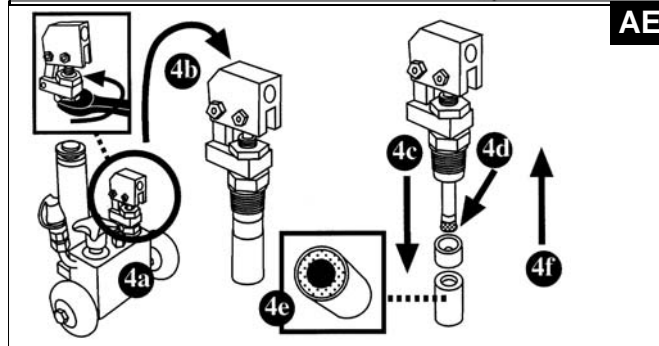
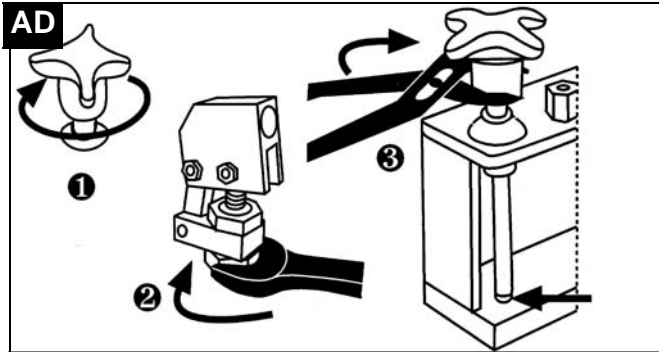

VIII. TROUBLESHOOTING

PROBLEM: Load is not, or not completely lifted (Pic AD)

CAUSE	REPAIR
Allowed load capacity exceeded	Use jack with higher load or additional jack
Air-vent screw gotten dirty	Clean air-vent screw with compressed air
1. Lowering screw is not or not correctly closed	Close discharging screw firmly clockwise
2. Adjusting screw is loose	Close firmly with open-end wrench (size 27)
3. Fit of ball of lowering screw on bottom side is leaky	Close firmly several times with pliers to form a new fit
4. Button-type collar seal shows fissuring	Change collar seal

- 4a) Open (anti-clockwise) and remove pressure screw (open-end wrench size 27)
- 4b) Take out complete insert
- 4c) Remove jack cylinder and distance sleeve downwards (no distance sleeve for V5)
- 4d) Remove collar seal and mount a new one (oil slightly first)
- 4e) Check carefully before assembling, that the copper ring on the bottom side of cylinder is inserted correctly (grease slightly for better fixing of the ring). Use new copper rings.
- 4f) Insert pressure piston into distance sleeve and jack cylinder and finally mount in complete insert vice versa.

5. Lack of oil (Pic AC)	Top up oil
6. Valve is dirty or defective (Pic AF)	Clean or replace valve

After emptying used oil (check Pic AB/AC, steps 1-6) and removing complete insert (actuating support for pressure piston, pressure screw, pressure piston and jack cylinder; check Pic AE, steps 4a / 4b), you must

- 6a) pull out the valve (e.g. with a magnetic tool) and then
 - 6b) blow out with compressed air or better use a new valve and
 - 6c) put the valve in and the complete insert again.
- Then tighten the pressure screw firmly (clockwise) and at last fill in new oil (amount and specification see table on page 7 below)

FAULT: Load moves up-wards and sinks again (Pic AG)

Check first and ensure yourself, that topic 2,3 and 6 are not the cause

CAUSE	REPAIR
7. Washer shows fissuring	Replace washer

- 7a) Open lowering screw
- 7b) Loosen the pressure screw
- 7c) Loosen guiding nut for lifting piston (with hinge-type pin-face spanner for round nuts with double drilled holes in one face)
- 7d) Pull out lifting piston
- 7e) Loosen snap ring (w. straight snap ring pliers for outerrings) on the bottom side of the lifting piston
- 7f) Remove washer, mount on new washer and assemble vice versa.



Lifting and Moving Solutions

www.gksweb.com

**OPERATING AND MAINTENANCE INSTRUCTIONS No. 09/2011 FOR GKS-PERFEKT
TOE JACK MODEL V**

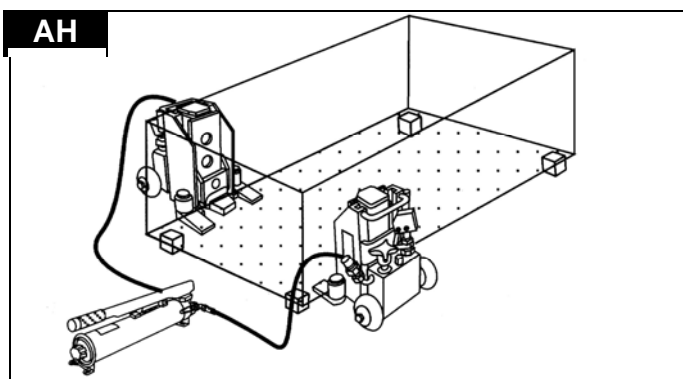

IX. EXTRAS

SEPARATE HYDRAULIC PUMPS (Pic AH)

Two or more jacks can be coupled together by an external pump. For this reason the load capacity can be doubled. Both jacks are only operated by a single person via this pump. Separate pumps, which are adjusted to the maximum allowed pressure, are offered in the following types:

- **Separate pump PV** for manual operation (Pic AH)
- The **electrical pump PE** (no pic)

⚠ Note: The hydraulic function is guaranteed only if both jacks are loaded evenly.

When you use two jacks, which are operated via a separate pump, you always must find out the centre of gravity first.

So first read the special operating instructions, for separate pumps carefully, which accompany each GKS pump!

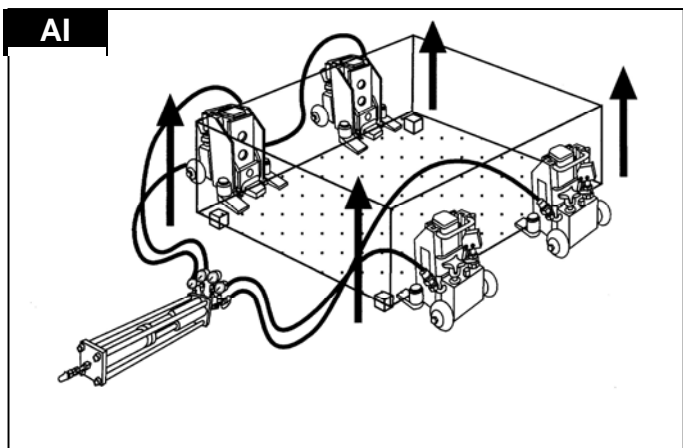

SEPERATE HYDRAULIC PUMPS (Pic AH)

Safety advice: When using pumps from other manufacturers, you always must assume, these pumps are not adjusted to the maximum allowed pressure. It may be possible, therefore the rated capacity of the jack is exceeded or is not reached. Furthermore the couplings are different. Thus always use original GKS separate pumps!

HYDRAULIC SYNCHRONOUS PUMP QUADRO (Pic Ai)

For synchronous lifting up to 88,000 lbs.(40 tons). Deliverable in manual or electrical version. 4 jacks are coupled together by the QUADRO and are only operated via this pump. Synchronous lifting of machines or loads is guaranteed, even if the center of gravity is not exact in the center of the load.

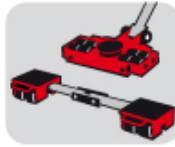
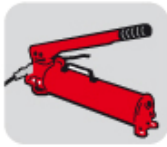
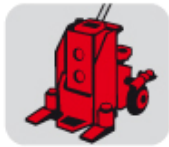

Lifting and Moving Solutions

www.gksweb.com

**OPERATING AND MAINTENANCE INSTRUCTIONS No. 09/2011 FOR GKS-PERFEKT
TOE JACK MODEL V**

**X. OTHER TIPS
WARRANTY**

The warranty period is 5 years, beginning with the date of purchase and covering material and construction. Unauthorized repair within this period leads to the lapse of the warranty.

SERVICE AND REPAIR

■ **Service, parts lists and orders**

Our number for quick information, trouble shooting or spare parts order is

CUSTOMER SERVICE (Springfield, OH 45505)

phone: +1 (937) 324 8867

Fax: +1 (937) 324 8171

e-mail: info@gksweb.com

■ **Repair**

Expert and qualified upkeep and repair after a long time of use are completed by our experts. Please send the jack to our address as stated on page 1 below left.

■ **Yearly check- up**

We recommend a yearly check-up of the jack, completed by an expert, to ensure the full ability of use. Ask for it!

SPECIAL DESIGNS

Our design department realizes special design solutions for all kinds of lifting and moving problems upon customer`s request. Give us a call , a fax or an e-mail!

XI. DECLARATION OF CONFORMITY

This is to confirm, that the GKS Hydraulic Lifting Jack Type V

Model	V5	V10	V15	V20
Artikel-no.	10181	10182	10183	10184
Year of manufacture:	1994	1994	2001	1994

complies with the following relevant specific standards:

- EC directive on machinery in the version of 2006/42/EC, Appendix IIA

Applied harmonised standards, especially

- DIN EN ISO 12100-1 : 2004 Safety of machines, basic principles for design; part 1: basic terminology, methodology
- DIN EN ISO 12100-2 : 2004 Safety of machines, general terms, general principles for design; part 2: technical principles and specifications

Applied national technical specifications, especially

- UVV (VBG8)/10.93: Regulation for preventing accidents
- ANSI / ASMI (USA)

Georg Kramp GmbH & Co KG
GKS Perfekt Lifting and Moving Equipment
70736 Fellbach/Germany

01st October 2011

Managing Director